

IMPROVED AR15 W/ OPTIC 25M ZERO TARGET

FOR A 100M ZERO

CALIBRATED FOR 1/2 MOA CLICK ADJUSTMENTS

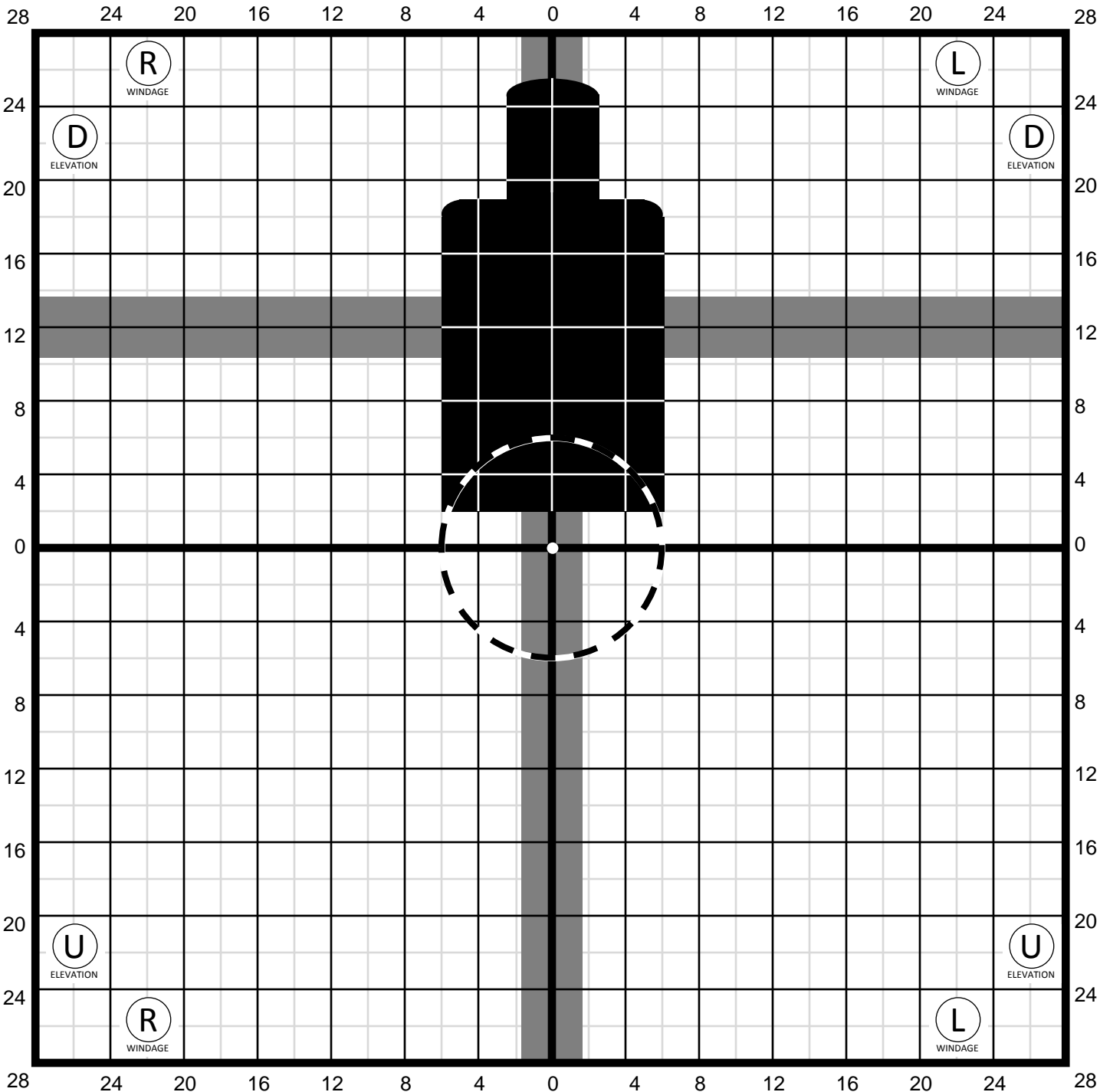

1. AIM CENTER MASS OF SILHOUETTE TARGET USING REFERENCE CROSSHAIRS FOR ASSISTANCE. ADJUST SIGHTS TO BRING BULLET IMPACT AS CLOSE AS POSSIBLE TO CENTER OF CIRCLE.
2. YOU ARE NOW ZEROED FOR 100 METERS.

TARGET BY: JUSTIN COLTER



IMPROVED AR15 W/ OPTIC 25M ZERO TARGET

FOR A 100M ZERO

CALIBRATED FOR 1/2 MOA CLICK ADJUSTMENTS

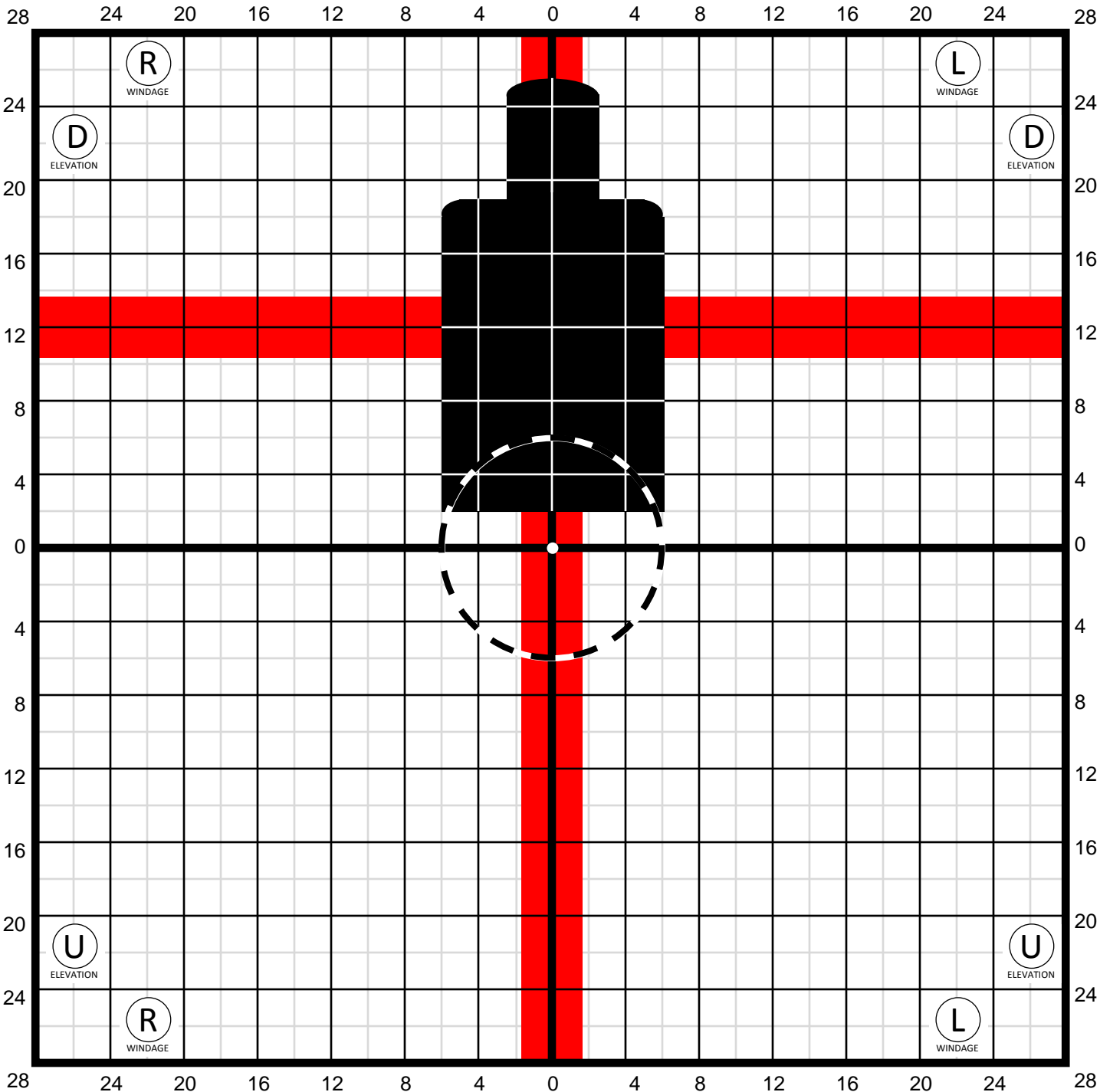

1. AIM CENTER MASS OF SILHOUETTE TARGET USING REFERENCE CROSSHAIRS FOR ASSISTANCE. ADJUST SIGHTS TO BRING BULLET IMPACT AS CLOSE AS POSSIBLE TO CENTER OF CIRCLE.
2. YOU ARE NOW ZEROED FOR 100 METERS.

TARGET BY: JUSTIN COLTER



IMPROVED AR15 W/ OPTIC 25M ZERO TARGET

FOR A 100M ZERO

CALIBRATED FOR 1/2 MOA CLICK ADJUSTMENTS

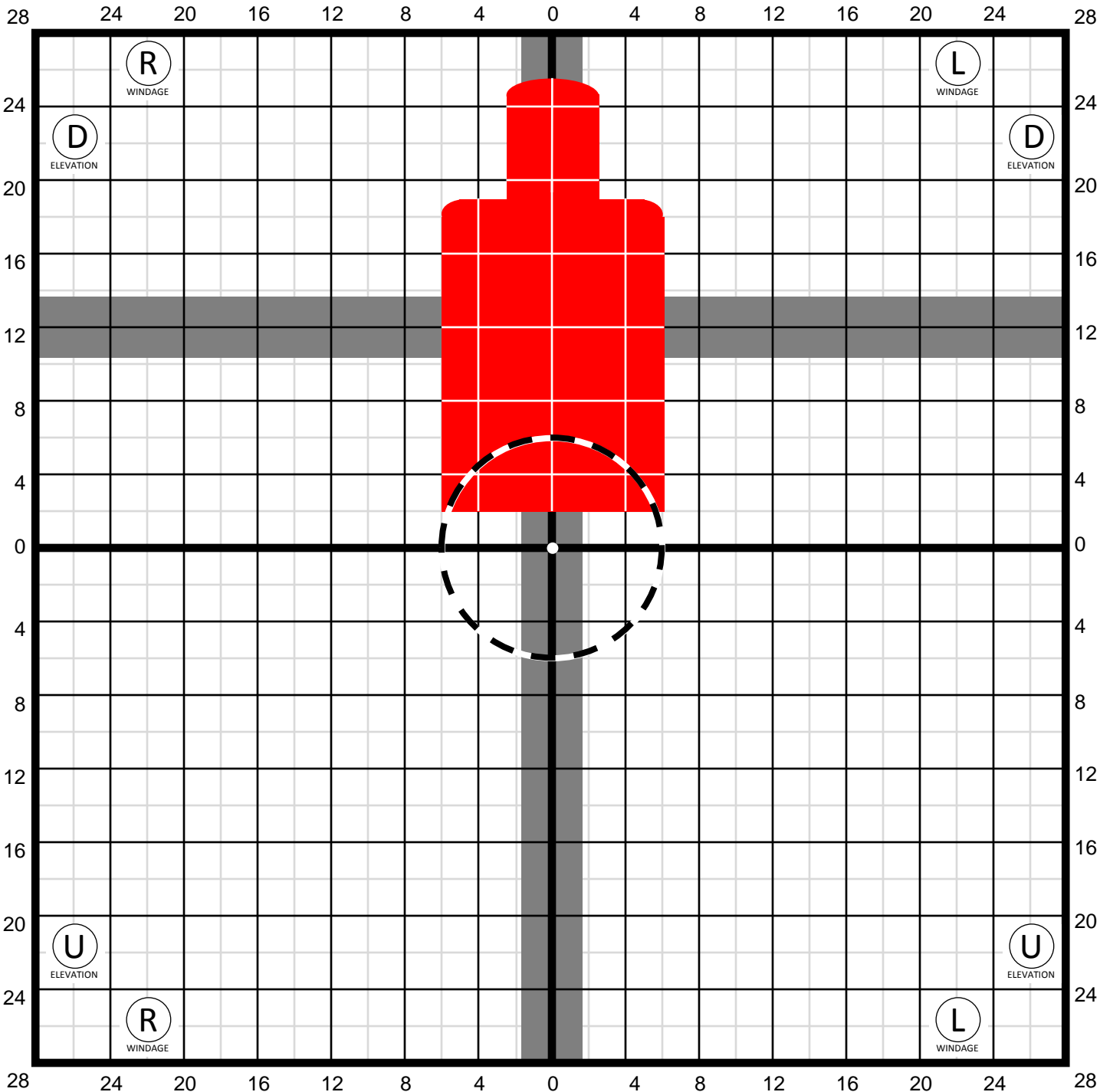

1. AIM CENTER MASS OF SILHOUETTE TARGET USING REFERENCE CROSSHAIRS FOR ASSISTANCE. ADJUST SIGHTS TO BRING BULLET IMPACT AS CLOSE AS POSSIBLE TO CENTER OF CIRCLE.
2. YOU ARE NOW ZEROED FOR 100 METERS.

TARGET BY: JUSTIN COLTER



IMPROVED AR15 W/ OPTIC 25M ZERO TARGET

FOR A 100M ZERO

CALIBRATED FOR 1/2 MOA CLICK ADJUSTMENTS

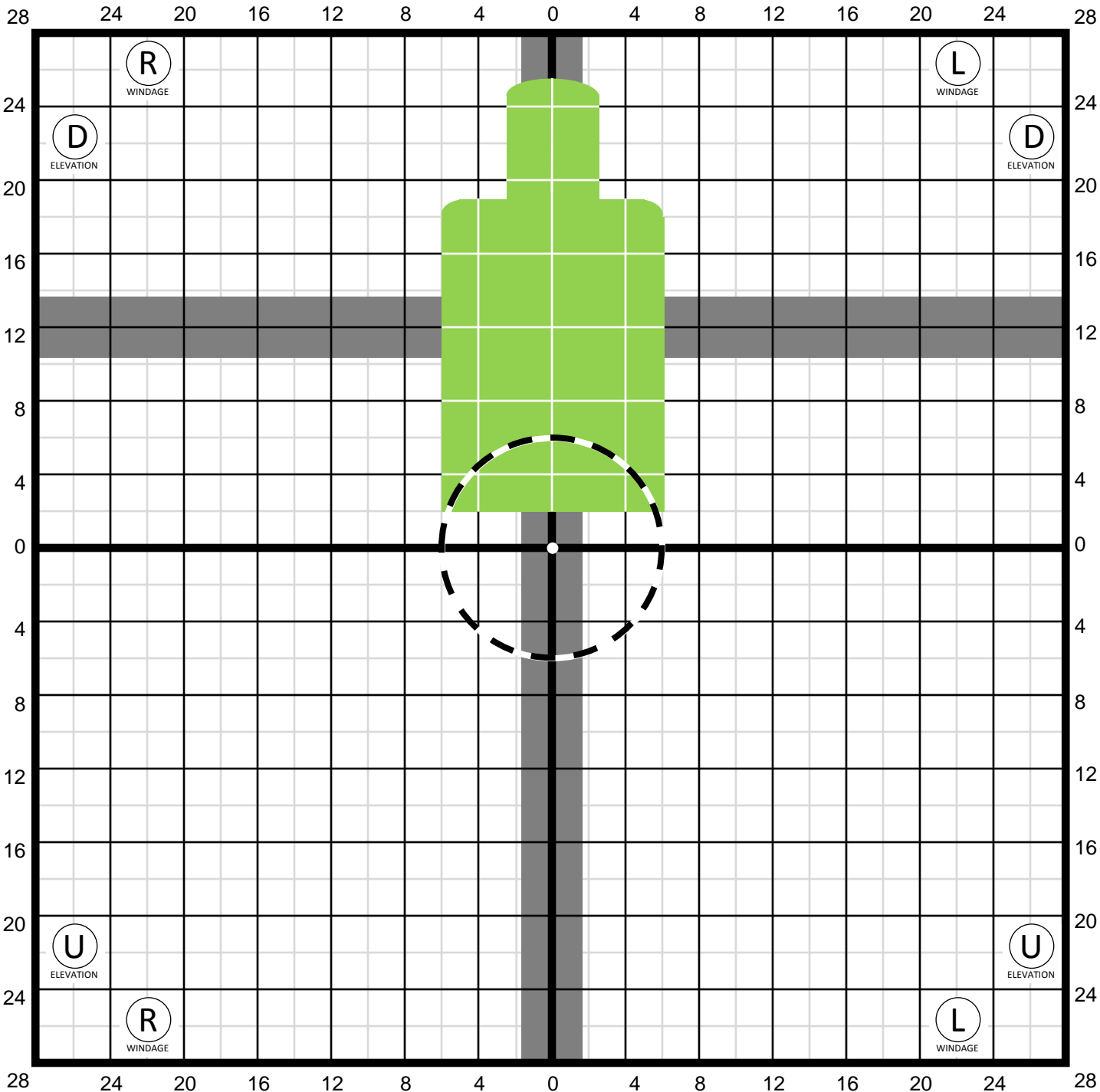

1. AIM CENTER MASS OF SILHOUETTE TARGET USING REFERENCE CROSSHAIRS FOR ASSISTANCE. ADJUST SIGHTS TO BRING BULLET IMPACT AS CLOSE AS POSSIBLE TO CENTER OF CIRCLE.
2. YOU ARE NOW ZEROED FOR 100 METERS.

TARGET BY: JUSTIN COLTER



IMPROVED AR15 W/ OPTIC 25M ZERO TARGET

FOR A 100M ZERO

CALIBRATED FOR 1/2 MOA CLICK ADJUSTMENTS

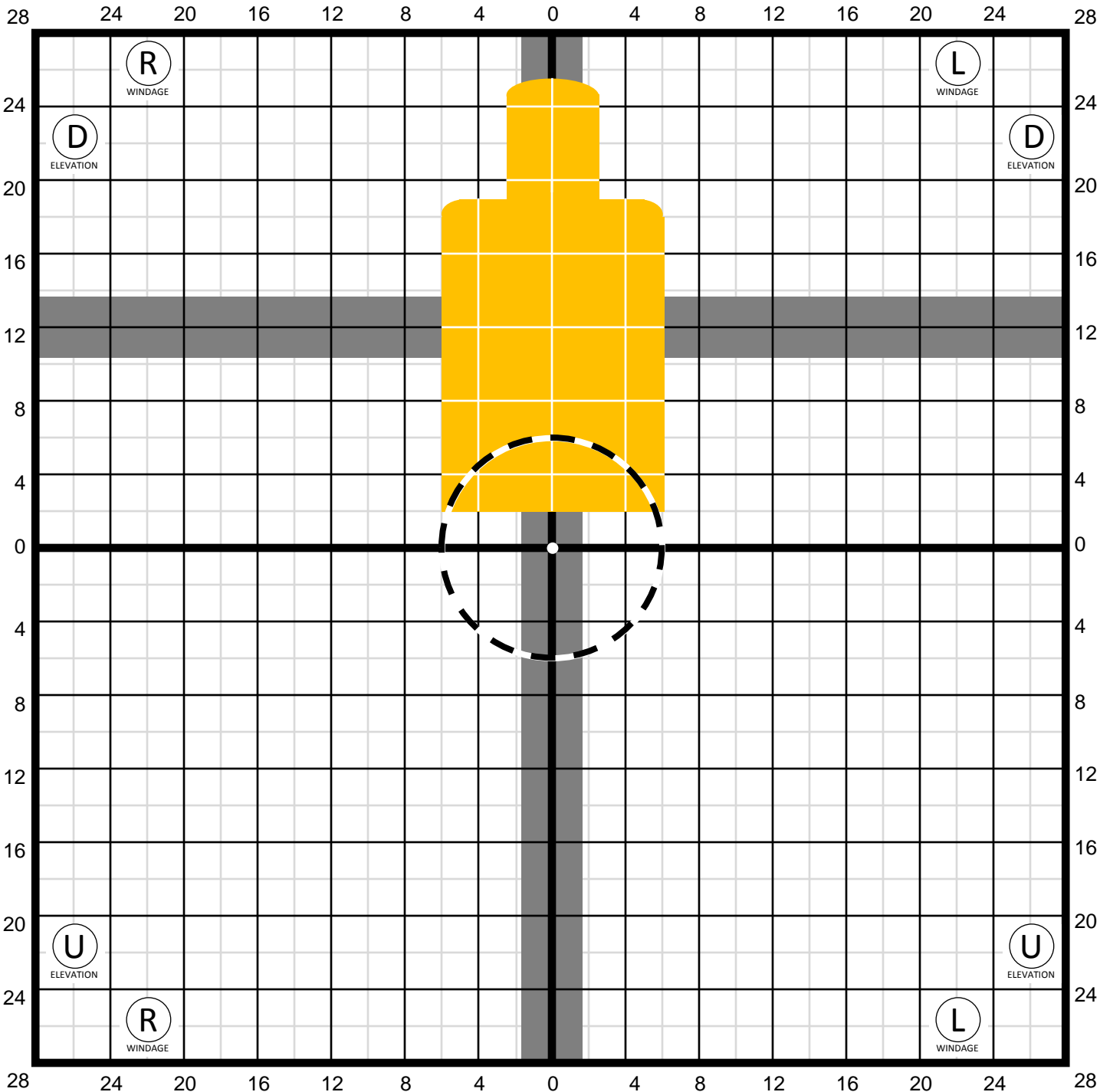

1. AIM CENTER MASS OF SILHOUETTE TARGET USING REFERENCE CROSSHAIRS FOR ASSISTANCE. ADJUST SIGHTS TO BRING BULLET IMPACT AS CLOSE AS POSSIBLE TO CENTER OF CIRCLE.
2. YOU ARE NOW ZEROED FOR 100 METERS.

TARGET BY: JUSTIN COLTER

